

## Guided Stuffing Box Assembly - Designed for All Plunger Pump Brands

*Engineered for plunger and packing wear resistance.*

A new parts retrofit package is available for all makes and models of plunger pumps - **The guided stuffing assembly**. The Thrust load from the eccentric motion is absorbed by the plunger guide system ensuring that the plunger remains stable through the entire stroke motion. The plunger guide is the primary guiding force, preventing side load and plunger shift. A size specific plunger guide is engineered for each pump model, providing maximum performance for each unit.

Wastecorp also employs full length guide bar rollers that capture the entire stroke length of the plunger. Tolerances are set to Wastecorp's 0.0015" nom. No lubrication is required, allowing the rollers to last up to 200 times longer than conventional guide shoes and greatly extending packing and plunger life.



*The guided stuffing box assembly is increasingly specified by Consulting Engineers for new plunger pump projects like this one at a wastewater treatment plant upgrade.*

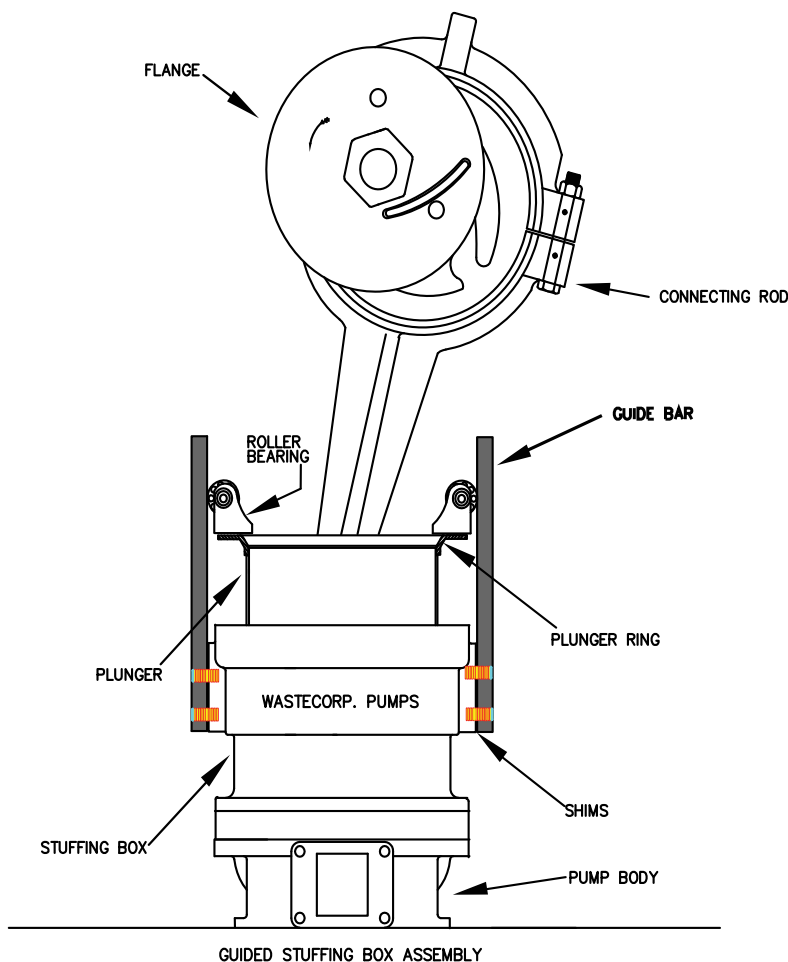

**Wastecorp Plunger Pumps®**  
**The Ultimate Sludge Fighters.**

Phone: 1-888-829-2783 Fax: 1-888-883-3320  
 International: 201-445-2882 E-mail: [info@wastecorp.com](mailto:info@wastecorp.com)  
 Website: <http://www.wastecorp.com>